

# POLIPASTO ELÉCTRICO



## RHINO HOIST CHAIN HOIST & LIFTING

### CARACTERÍSTICAS TÉCNICAS

- Desde 3.2ton hasta 10ton.
- Voltaje (V): 220/440-220/380 Hz60.
- Longitud estándar SH.

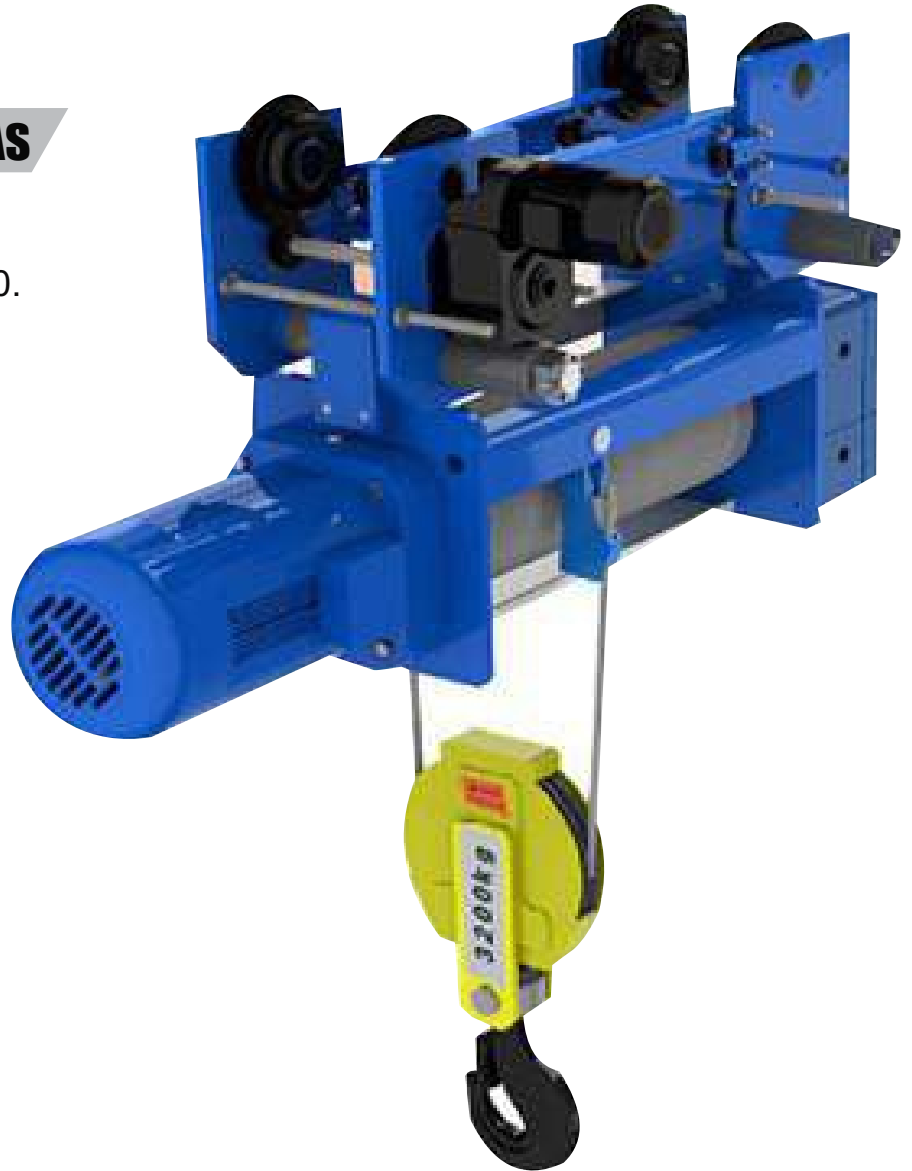
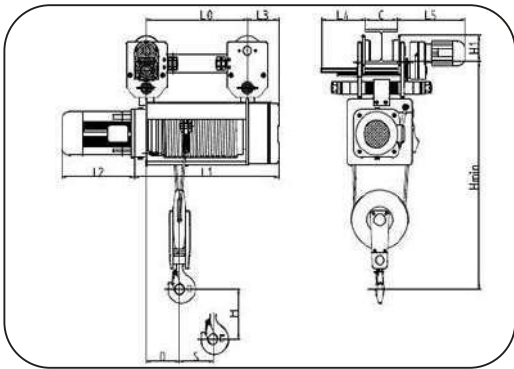

### DATOS TÉCNICOS

| Type | Capacity (t) | Classification | Rope reeving | Lifting speed m/min. | Lifting motor Kw | Traveling speed m/min. | Traveling motor Kw | L2(mm)       |              | Suitable for rail C(mm) |         | L5 mm | L4 mm | H1 mm | Hmin mm | L3 mm | D mm | S mm    | Lifting height (H) |      |      |      | Size |
|------|--------------|----------------|--------------|----------------------|------------------|------------------------|--------------------|--------------|--------------|-------------------------|---------|-------|-------|-------|---------|-------|------|---------|--------------------|------|------|------|------|
|      |              |                |              |                      |                  |                        |                    | Single Speed | Double Speed | I                       | H       |       |       |       |         |       |      |         | 6m                 | 9m   | 12m  | 15m  |      |
| SH4  | 3.2          | M4             | 4/1          | 3.6                  | 3                | 20                     | 0.37               | 350          | 535          | 110-180                 | 180-420 | 375   | 282   | 121   | 1105    | 147   | 142  | 0.0174H | 716                | 924  | 1132 | 1340 | LO   |
|      |              |                |              | 3.6/1.2              | 3/1              | 20/6.7                 | 0.37/0.12          |              |              |                         |         |       |       |       |         |       |      |         | 925                | 1133 | 1341 | 1549 | L1   |
| SH5  | 6.3          | M4             | 4/1          | 3.5                  | 4.5              | 20                     | 0.55               | 380          | 600          | 130-180                 | 180-420 | 429   | 278   | 151   | 1225    | 161   | 157  | 0.0182H | 757                | 975  | 1193 | 1411 | LO   |
|      |              |                |              | 3.5/0.8              | 4.5/1.1          | 20/6.7                 | 0.55/0.18          |              |              |                         |         |       |       |       |         |       |      |         | 986                | 1204 | 1422 | 1640 | L1   |
| SH6  | 10           | M4             | 4/1          | 3.8                  | 7.5              | 20                     | 0.75               | 460          | 645          | 140-450                 | 180-450 | 434   | 308   | 179   | 1314    | 194   | 175  | 0.0191H | 832                | 1061 | 1290 | 1519 | LO   |
|      |              |                |              | 3.8/0.9              | 7.5/2.0          | 20/6.7                 | 0.75/0.25          |              |              |                         |         |       |       |       |         |       |      |         | 1101               | 1330 | 1559 | 1788 | L1   |

