

POLIPASTO ELÉCTRICO



RHINO HOIST CHAIN HOIST & LIFTING

CARACTERÍSTICAS TÉCNICAS

- Desde 1ton hasta 5ton.
- Voltaje (V): 220/440-220/380 Hz60.
- Longitud estándar SH.

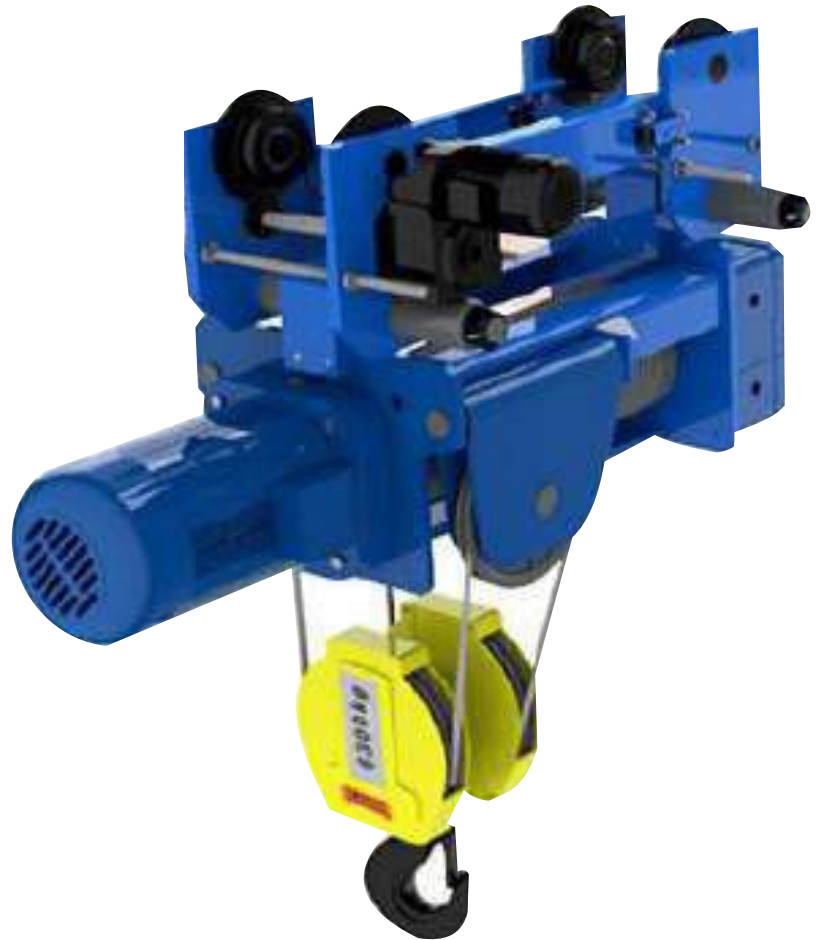
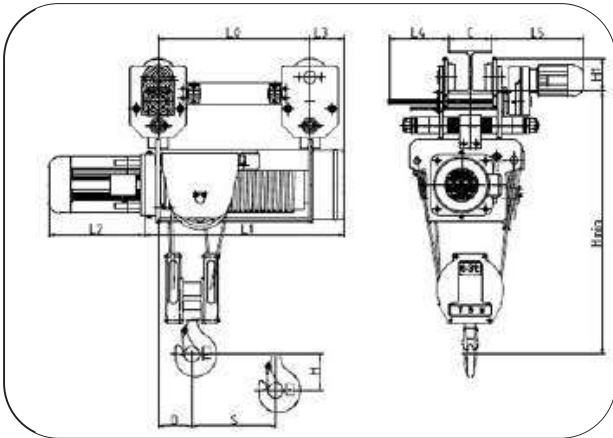

DATOS TÉCNICOS

Type	Capacity (t)	Classification	Rope reeving	Lifting speed	Lifting motor	L2(mm)		O mm	A mm	A0 mm	B mm	Hmin mm	L3 mm	S mm	Lifting height (H)				Size
				m/min.	Kw	Single Speed	Double Speed								9m	12m	18m	24m	
SH3	1	M4	2/1	8.4	1.5	300	500	13	278	215	253	455	163	0.0161H	431	528	722	916	LO
				8.4/2.1	1.5/0.4										671	778	972	1166	L1
															113	113	113	113	D
SH4	2	M4	2/1	7.2	3	350	535	18	335	265	310	578	181	0.0174H	494	648	856	1064	LO
				7.2/2.4	3/1										771	925	1133	1341	L1
															148	198	198	198	D
SH5	3.2	M4	2/1	7	4.5	380	600	18	370	300	346	649	198	0.0182H	431	683	901	1119	LO
				7/1.6	4.5/1.1										671	986	1204	1422	L1
															115	211	211	211	D
SH6	5	M4	2/1	7.6	7.5	460	645	26	408	325	381	739	226	0.0191H	524	768	997	1126	LO
				7.6/1.8	7.5/2.0										827	1101	1330	1559	L1
															161	258	258	258	D

